

Technical Datasheet

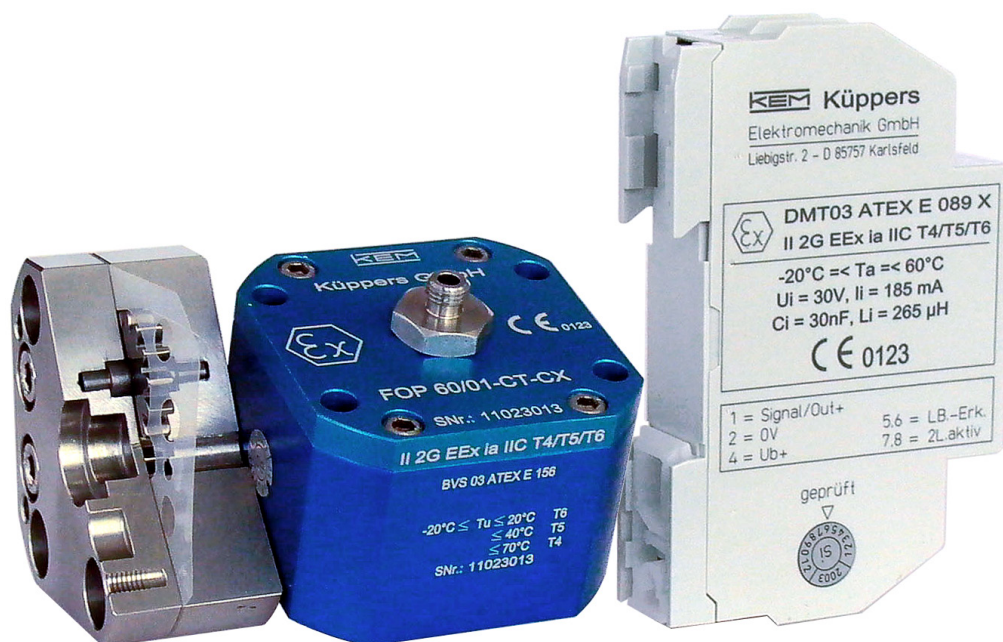

FOP60 and OPTV

Fibre-Optic Amplifier and Receiver

Application

The FOP is a fibre-optic amplifier for KEM gear flow meters used in high-voltage applications. Its integral pickup detects the r.p.m. of the gears and the FOP provides a flow-proportional light pulse signal. The OPTV receiver will convert the light pulses into a current or voltage squarewave signal which may be used for evaluation.

Applications

- Interference-free pulse detection
- No electrical connection to OPTV receiver
- Blue-anodised aluminium housing
- Light weight and handy design

Technical Data

FOP fibre-optic amplifier

Power supply	lithium battery
Battery lifetime	max. 2 years with 24h-operation
Ambient temperature	-20 °C up to +50 °C
Frequency range	7 up to 1,000 Hz
Weight	approx. 190 g
Schutzart	IP65
Ex-protection, IS	 II 2 G EEx ia IIC T4/T5/T6, BVS 03 ATEX E 156
Housing	IP65, anodised aluminium (for dimensions please see drawings)

Fibre-optic cable, silicone-free, ready-to-wire

Type	OKE1000-C, orange-coloured
Cable Ø	5.5 mm
Plug Ø	< 8,5 mm
Bending radius	> 10/50 mm
Tensile strength	250/100 N
Bending strength in alternate directions	> 10.000
Ambient temperature	-30 °C bis +80 °C
Plug type	2x LWST1000 65
Protection class	IP 65
Cable length	max. 10 m
Wire tip material	nickel-silver (ARCAP)

General

Dimensional drawing (mm) - FOP 60-XX-XX-SR

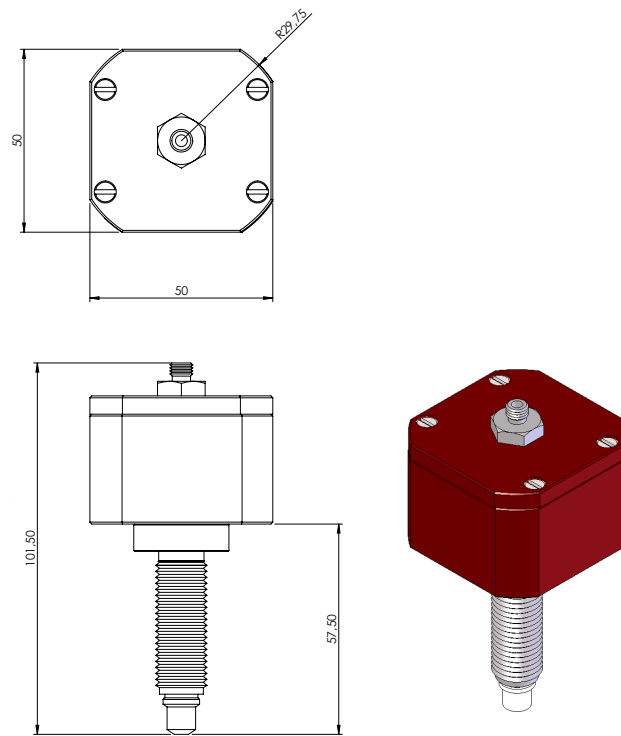

Maßzeichnung (mm) - FOP 60-XX-XX-SK

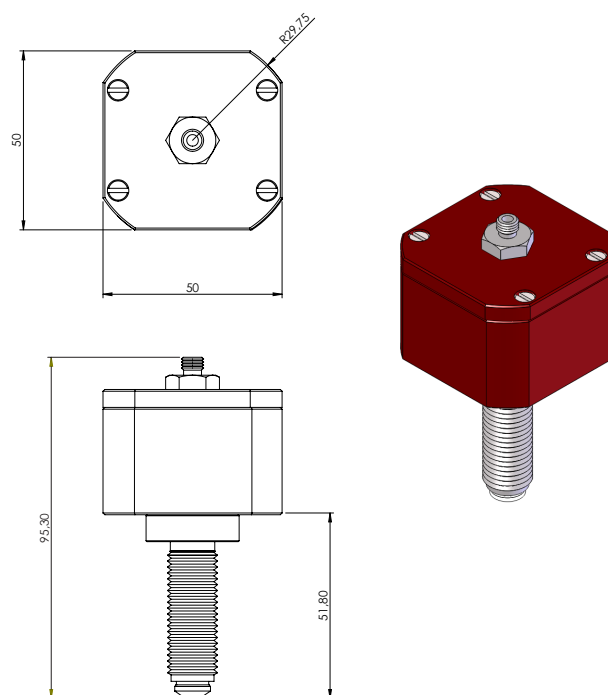

Dimensional drawing (mm) - FOP 60-01-CT-CX

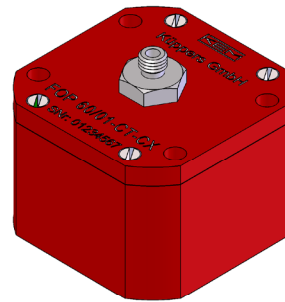
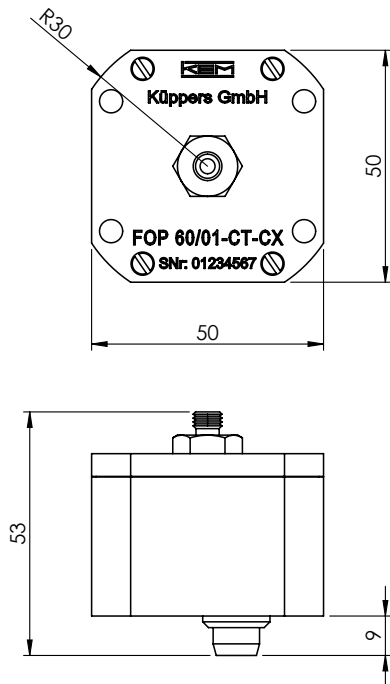

Technical Data - OPTV

OPTV-02/X light pulse receiver and converter

Ambient temperature	-20 °C up to +60 °C
Supply voltage	U_B : 7 up to 30 V
Quiescent current	$I_R < 1,1$ mA
Output	frequency output, constant pulsetime 500 µsec
Electrical data, alternatively	<p>voltage outputs (3-wire connection)</p> <p>a) active output high level: $U_{high} > U_B - 0.6 \text{ V} - 2.5 \text{ k}\Omega \times I_{out} \text{ (mA)}$ low level: $U_{low} < 0.6 \text{ V} + 1.3 \text{ k}\Omega \times I_{out} \text{ (mA)}$</p> <p>b) passive output high level: $U_{high} > U - I_{out} \text{ (mA)} \times 1.3 \text{ k}\Omega$ low level: $U_{low} < 0.6 \text{ V} + 1.3 \text{ k}\Omega \times I_{out} \text{ (mA)}$ U is the voltage applied at the output, max. 30 V</p> <p>current output (2-wire connection)</p> <p>a) for $U_B < 9 \text{ V}$ (NAMUR supply units) high level: $I_{high} > 2.2 \text{ mA}$ low level: $I_{low} < 1.1 \text{ mA}$</p> <p>b) for U_B 7 up to 30 V high level: $I_{high} = (U_B - 0.6 \text{ V})/1.3 \text{ k}\Omega + I_{low}$ low level: $I_{low} = (U_B - 4 \text{ V})/7.5 \text{ k}\Omega$</p>
Frequency range	3 up to 2,000 Hz according to flow meter
Electrical connection	two off 4-pin screw terminals for supply and output signals (cf. wiring schemes)
Ex protection	 II2 G EEx ia IIC T6, DMT 03 ATEX E 089X
Housing	grey-coloured polycarbonate for DIN hat top rail mounting

Dimensional drawing (mm) - OPTV

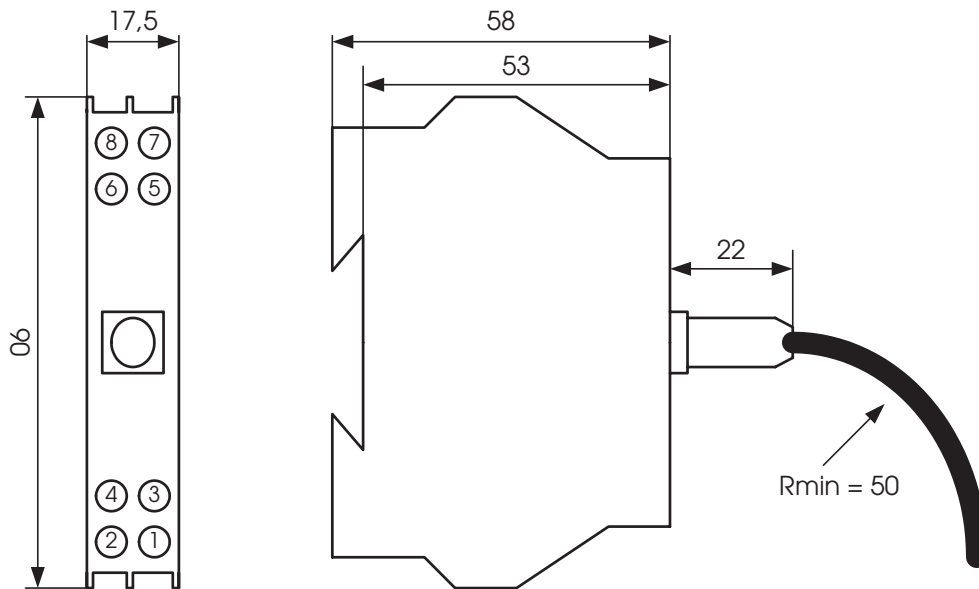

- 1 = signal/out+
- 2 = 0V
- 3 = n.c.
- 4 = UB+
- 5 = detection of line breakage
- 6 = detection of line breakage
- 7 = 2-wire active
- 8 = 2-wire active

connection via
screw terminals

- U_{max.} = 30V
- I_{max.} = 185mA
- C_i = 30nF
- L_i = 265μH

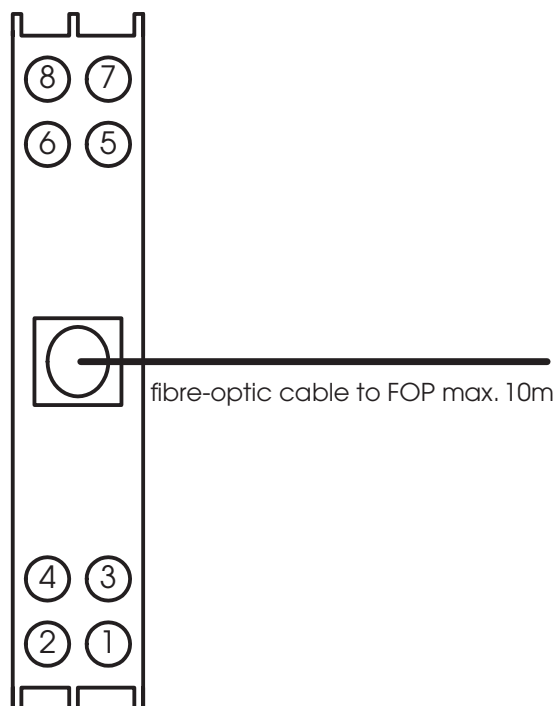

Electrical connection OPTV

3-wire passive

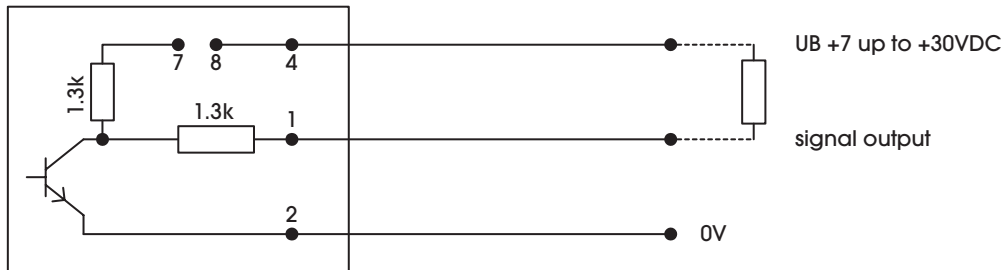

3-wire active

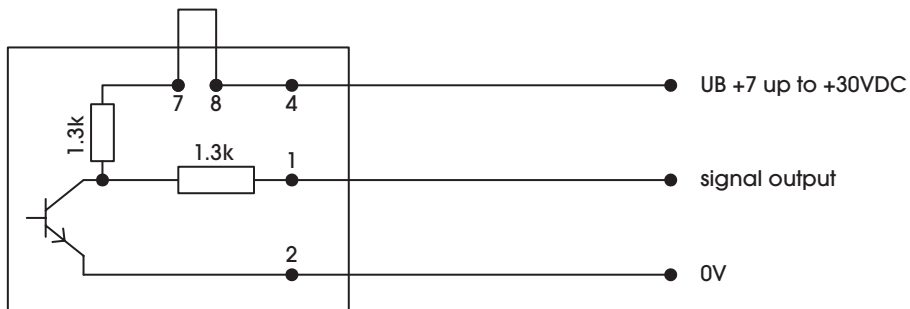

2-wire

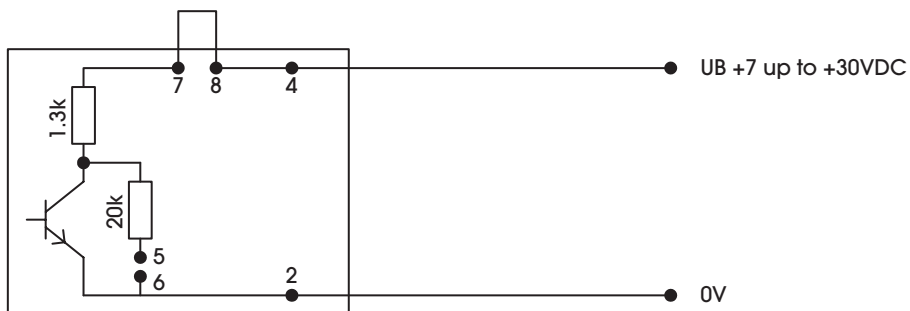

2-wire with KEM separation amplifier type EWS

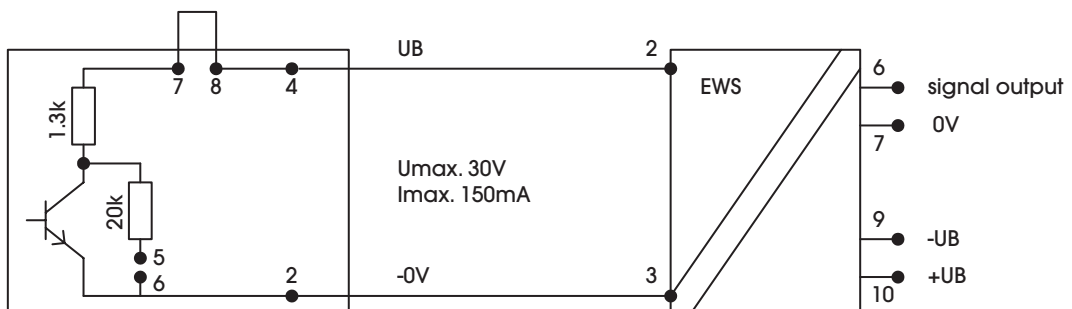

Ordering information

FOP60	-	X	X	-	X	X	-	X	X
Meter size									
ZHM01 with pickup to plug		0	1						
Optional		X	X						
Meter design									
Cartridge design					C	T			
Optional M14x1,5					X	X			
Pickup nose									
with threadless transducer in Cartridge design								C	X
short pickup with thread M14x1,5 for ZHM02-04								S	K
short pickup with thread M14x1,5 for ZHM01/*								S	R

Marking

FOP 60:

KEM Küppers Elektromechanik GmbH
 CE 0123 Ex II 2G Ex ia IIC T4/T5/T6
 DMT 03 ATEX E 156

FOP60/**-**_** Ser.Nr. 123456789
 -20 °C ≤ Ta ≤ 20 °C T6
 ≤ 40 °C T5
 ≤ 70 °C T4

OPTV:

KEM Küppers Elektromechanik GmbH
 CE 0123 Ex II 2G Ex ia IIC T4/T5/T6
 DMT 03 ATEX E 089X

OPTV-02 Ser.Nr. 123456789
 -20 °C ≤ Ta ≤ 60 °C

Ui = 30 V; li = 185 mA
 Ci = 30 nF; Li = 265 µH

The test sticker indicates year of building and person in charge of test.

Notes on installation

The following has to be adhered to:

- a) Installation instructions for electrical devices,
Installation instructions for associated intrinsically-safe devices,
The »Special conditions for safe use« as per EC-Type Examination Certificate
- b) The amplifier has to be installed in a way that the max. ambient temperature does under no circumstances exceed +50 °C (consider self heating).
- c) With cables care should be taken, that the max inductivity and capacity of the respective voltage or gas group are not exceeded.
- d) Exceeding or falling below the regular measuring range will cause invalid frequency output signals.
- e) Shielded cables are to be used as connecting lines.
- f) Generally, supplied units have to be connected by an expert according to EMC stipulations.
- g) The light pulse receiver must always be placed inside a housing with protection class IP20.
- h) When the light pulse receiver is installed inside a housing made of plastics or light alloy the material must be in accordance with paragraph 7.3.2 or 8 of EN50014:1997.
- i) The internal wiring in this housing must be in accordance with paragraph 6.4.11 and 7.6.e of EN50020:1994.
- j) Terminals or plug connections for the intrinsically safe current circuits must be arranged as per paragraph 6.3.1 or 6.3.2 of EN50020:1994.
- k) Terminals 5–6 and 7–8 must not be connected with an other device.

KEM Headquarter

Liebigstraße 5
85757 Karlsfeld
Deutschland

T. +49 8131 59391-0
F. +49 8131 92604

info@kem-kueppers.com

KEM Service & Repairs

Wetzeller Straße 22
93444 Bad Kötzing
Deutschland

T. +49 9941 9423-0
F. +49 9941 9423-23

info@kem-kueppers.com

*More distributors & partners can be found at:
www.kem-kueppers.com*