

Diaphragm seal

flange connection per DIN 11864-2

Type series DH....



Application area

- Food industry
- Pharmaceutical industry
- Biotechnology

Features

- Flush-mounted separating diaphragm of stainless steel, laser welded
- For pipes per EN 10357 (DIN11850), EN 1127 and ASME-BPE
- Volume optimised diaphragm base
- EHEDG-certified
- System fillings for different applications
- Measuring device connection:
 - directly welded
 - directly screwed
 - with temperature decoupler
 - with capillary

Options

- Certificates
 - Material certificate acc. to EN 10204-3.1
- Electropolishing (wetted parts)
- Hygienic design with advanced surface quality

Application

Suitable for mounting to bourdon tube pressure gauges and pressure transmitters. The diaphragm seal with aseptic flange connection is used mainly for dead-zone free pressure measurement.

Technical data

Constructional design

Basic body:	Volume reduced diaphragm base Material: stainless steel mat.-no. 1.4404/1.4435 (316L)
Diaphragm:	Flat diaphragm
Material wetted parts:	Diaphragm: Stainless steel mat.-no. 1.4435 (316L) Basic body: Stainless steel mat.-no. 1.4404/1.4435 (316L)

Process connection

Design:	Aseptic connections per DIN 11864-2 <ul style="list-style-type: none">■ groove flange, model A■ coupling flange, model A Further connections upon request.
Nominal pressure / Nominal width:	See table

Sealing are not included in the scope of delivery.

Measuring device connection

See order details.
Material stainless steel mat.-no. 1.4301 (304)

System filling

See order details; further upon request.
Further details about pressure transmission fluids see general technical information TA_038.

Hygienic design

The surface roughness of the wetted parts made of stainless steel are executed according to EHEDG Doc.8 and ASME BPE SF3.
In case of choosing the additional feature HY, we guarantee the following surface roughness values:

Diaphragm foil:	$Ra \leq 0.38 \mu\text{m}$
Laser welds:	$Ra \leq 0.76 \mu\text{m}$
Turned parts:	$Ra \leq 0.76 \mu\text{m}$

Further versions of hygienic design upon request.

Temperature error

In order to optimise the system we provide a detailed error calculation upon request.

Weight

See table.

Further information about diaphragm seals see general technical information TA_031.

Measuring device connection

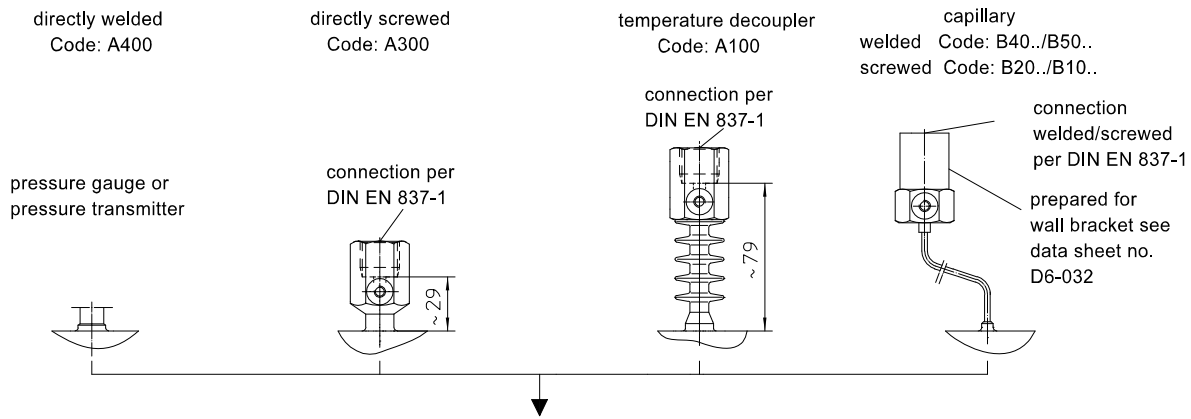

Dimensions

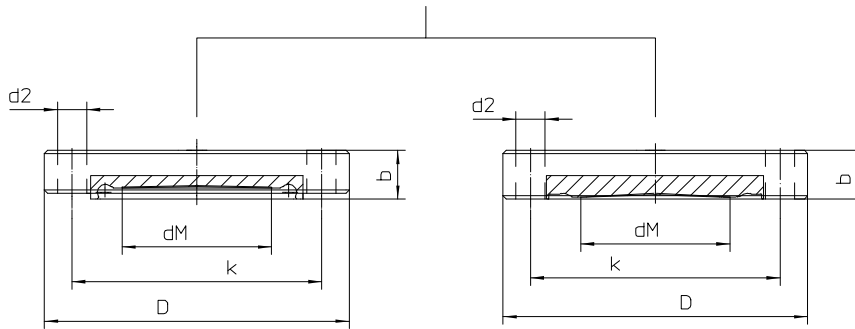

aseptic flange with groove, model A

aseptic coupling flange, model A

Flange connections per DIN 11864-2, model A

Dimensions (mm) for pipes per EN 10357 (DIN 11850), pipe dimensions per DIN 11866 table 1 model A									
DN	PN	pipe inside Ø	D	dM	k	d2	no. bore holes	b	weight
	bar								approx. kg
25	25	26	70	24	53	9	4	17	0.5
32	25	32	76	27	59	9	4	17	0.7
40	25	38	82	34	65	9	4	15	0.9
50	16	50	94	46	77	9	4	15	1.0
65	16	66	113	62	95	9	8	20	1.7

Dimensions (mm) for pipes per EN ISO 1127, pipe dimensions per DIN 11866 table 1 model B									
nominal width	PN	pipe inside Ø	D	dM	k	d2	no. bore holes	b	weight
DN/OD	bar								approx. kg
33.7	25	29.7	74	27	57	9	4	17	0.6
42.4	16	38.4	82	34	65	9	4	15	0.9
48.3	16	44.3	88	40	71	9	4	15	1.0
60.3	16	56.3	103	51	85	9	4	15	0.9

Dimensions (mm) for pipes per ASME-BPE, pipe dimensions per DIN 11866 table 1 model C (suitable for pipes per BS 4852 Part 3 and O.D. Tube)									
DN/OD	PN	pipe inside Ø	D	dM	k	d2	no. bore holes	b	weight
inch	bar								approx. kg
1"	25	22.1	66	21	49	9	4	17	0.4
1 1/2"	25	34.8	79	34	62	9	4	17	0.8
2"	16	47.5	92	46	75	9	4	15	1.0
2 1/2"	16	60.2	107	51	89	9	4	20	1.5

Order details

Diaphragm seal flange connection per DIN 11864-2

Type series DH....

Order details diaphragm seal DH...			
DH1..	design	for pipes per EN 10357 (DIN 11850), pipe dimensions per DIN 11866 table 1, model A	
		<u>process connection</u>	<u>pipe inside Ø di</u>
100	nominal width DN	DN 25, PN 25	26 mm
200		DN 32, PN 25	32 mm
300		DN 40, PN 25	38 mm
400		DN 50, PN 16	50 mm
500		DN 65, PN 16	66 mm
DH2..	design	for pipes per EN ISO 1127, pipe dimensions per DIN 11866 table 1, model B	
		<u>process connection</u>	<u>pipe inside Ø di</u>
100	nominal width DN/OD	DN 33.7 (Rohr 33.7 x 2), PN 25	29.7 mm
200		DN 42.4 (Rohr 42.4 x 2), PN 16	38.4 mm
300		DN 48.3 (Rohr 48.3 x 2), PN 16	44.3 mm
400		DN 60.3 (Rohr 60.3 x 2), PN 16	56.3 mm
DH3..	design	for pipes per EN ISO 1127, pipe dimensions per DIN 11866 table 1, model B (suitable for pipes per BS 4825 Part 3)	
		<u>process connection</u>	<u>pipe inside Ø di</u>
100	nominal width DN/OD	1", PN 25	22.1 mm
300		1 1/2", PN 25	34.8 mm
400		2", PN 16	47.5 mm
500		2 1/2", PN 16	60.2 mm
S1001	aseptic flange connection	<u>Flange connection per DIN 11864-2¹</u>	
S1003		aseptic flange with groove, model A	
	surface roughness	aseptic coupling flange, model A	
HY		standard	
A400	connection to measuring device	Hygienic version as per EHEDG Doc.8 and ASME BPE SF3	
A300		directly	welded
A100			screwed G1/2
B40..		with temperature decoupler	screwed G1/2
B20..		with capillary	welded
B50..			screwed G1/2
B10..		with capillary and stainless steel protective tube	welded
11			screwed G1/2
12		capillary length	1 m
13			1.6 m
14			2.5 m
21			4 m
15			5 m
23			6 m
16	7 m		
17	8 m		
9	10 m		
7	material	sonstige	
		wetted parts stainless steel mat.-no. 1.4435 (316L)	
		<u>pressure transmission fluid</u>	<u>temperature range³</u>
L22	system filling ²	synthetic oil, free of silicone FD1, standard	-10...140 °C
L23		synthetic oil, free of silicone FD1, please specify max. temperature	-40...230 °C
L15		glycerine/water FGW	-30...110 °C

Additional features (to be indicated in case of need, only)

W1020	material certificate per EN 10204-3.1, wetted parts
W4035	electropolishing of wetted parts

Order code (example): DH1100 - S1001 - HY - A4007 - L22 - ...

¹ EHEDG certified only in connection with hygienic design (order code option HY)

² further and detailed informations to pressure transmission fluids see TA_038

³ max. media temperature for pressures > 0 bar rel.