

Diaphragm seal

screw-in thread ASEPTIC, flush-mounted o-ring

Type series DE2160



Application area

- Food industry
- Pharmaceutical industry
- Biotechnology

Features

- Aseptic sealing with flush-mounted o-ring according to the EHEDG guidelines:
 - connection without gap and offset
 - defined metal stop
 - defined seal positioning
- Flush-mounted diaphragm of stainless steel, laser welded
- Surface quality according to hygienic requirements
- Fast and easy mounting
- The measuring system can be positioned as required by means of a rotatable screwed plug (G3/4 A und G1 A)
- System fillings for different applications
- Measuring device connection
 - directly welded
 - directly screwed
 - with capillary

Options

- Certificates
 - Material certificate acc. to EN 10204-3.1
- Electropolishing (wetted parts)
- Higher surface quality upon request
- Special materials upon request

Application

The diaphragm seal with flush-mounted o-ring is used mainly for dead-zone free pressure measurement. It is suitable for mounting to pressure transmitters and gauges. The rotatable connection (G3/4 A and G1 A) allows the measuring system to be positioned freely.

Technical data

Constructional design

Basic body:	Volume reduced diaphragm base Material: stainless steel mat.-no. 1.4435 (316L)
Diaphragm:	Flat diaphragm
Material wetted parts:	Diaphragm: Stainless steel mat.-no. 1.4435 (316L), alternative with delta ferrite content < 3% Basic body: Stainless steel mat.-no. 1.4435 (316L), alternative with delta ferrite content < 3% Further materials upon request.
Profile gasket: (non wetted)	Material: EPDM, optional FKM

Process connection

Design:	<ul style="list-style-type: none">■ G 3/4 A and G1 A with rotatable screwed plug. Due to the rotatable screw-in design no torsion forces are produced at the o-ring.■ G1/2 A with fixed screwed plug.
Tightening torque:	> 30 Nm
Nominal pressure:	max. 60 bar
O-ring: (wetted)	<ul style="list-style-type: none">■ Material EPDM, temperature range: -40...150 °C■ Material FKM (Viton) temperature range: -10...200 °C

Measuring device connection

See order details.
Material stainless steel mat.-no. 1.4301 (304)

System filling

See order details; further upon request.
Further details about pressure transmission fluids see general technical information TA_038.

Hygienic design

The wetted surfaces made of stainless steel are executed according to EHEDG Doc.8 and ASME BPE SF3.
We guarantee the following surface roughness values:

Diaphragm foil:	Ra ≤ 0.38 µm
Laser welds:	Ra ≤ 0.76 µm
Turned parts:	Ra ≤ 0.76 µm

Further versions of hygienic design upon request.

Temperature error

In order to optimise the system we provide a detailed error calculation upon request.

Weight

connection G1/2 A:	approx. 110 g
connection G3/4 A:	approx. 230 g
connection G1 A:	approx. 360 g

Further information about diaphragm seals see general technical information TA_031.

Further information about weld-on adapter see general technical information TA_009.

Measuring device connection

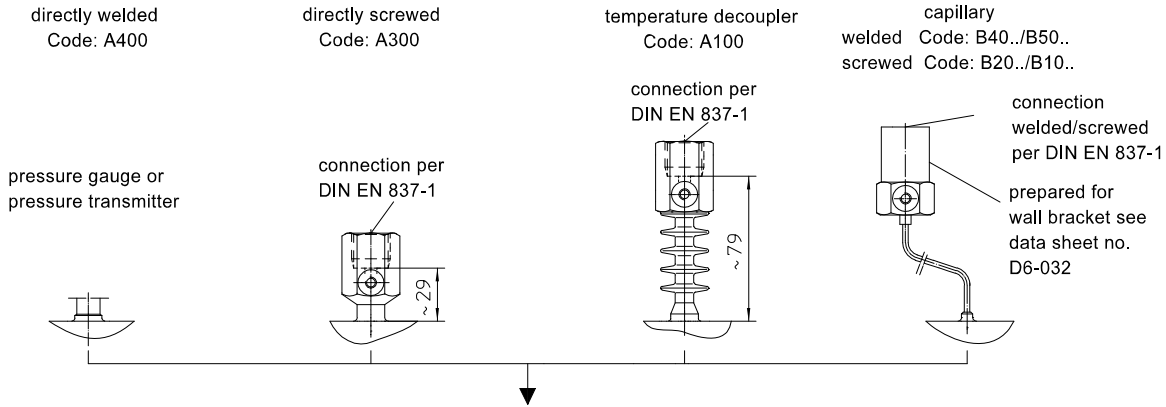

Dimensions

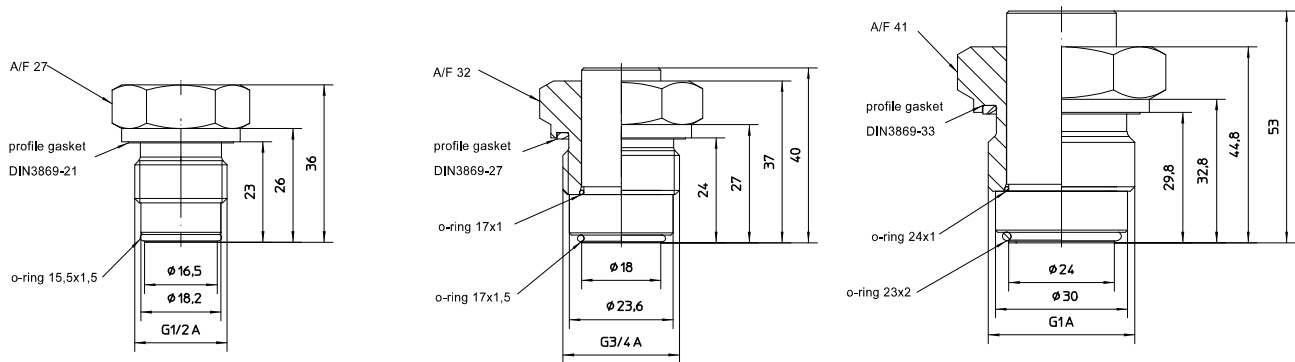

Alternative with knurled nut

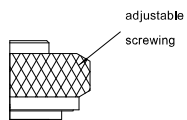

Weld-on adapters

Standard

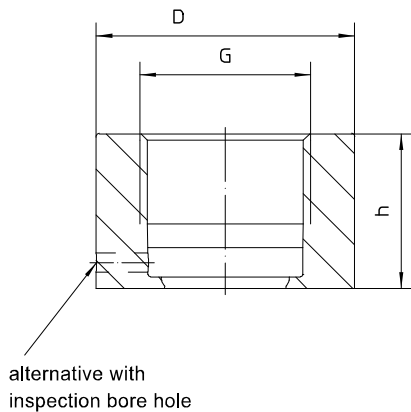

Prepared to fit on pipe ends

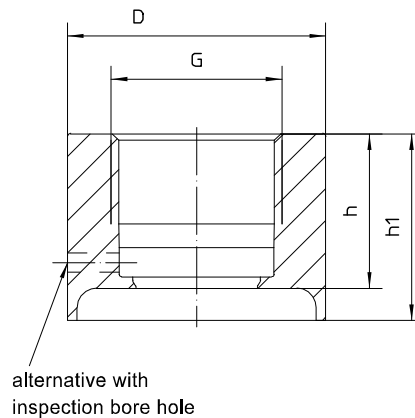

dimensions (mm)			
	D	h	h1
G1/2 "	29	23	28
G3/4 "	40	24	29
G1 "	40	29.8	34.8

Order details

Diaphragm seal screw-in thread ASEPTIC with flush-mounted O-ring Type series DE2160

Order details DE2160				
DE2160	design	Screw-in thread ASEPTIC with flush-mounted O-ring		
HY	surface roughness	Hygienic version as per EHEDG Doc.8 and ASME BPE SF3		
D110	process connection	G1/2" A with fixed screwed plug	hexagon nut	
D111			knurled nut	
D120		G3/4" A with rotatable screwed plug	hexagon nut	
D121			knurled nut	
D130		G1" A with rotatable screwed plug	hexagon nut	
D131			knurled nut	
E7	basic body material	stainless steel mat.-no. 1.4435 (316L)		
E7.9		stainless steel mat.-no. 1.4435 (316L) with delta ferrite content < 3 %		
E9		others		
G7	Diaphragm seal material	stainless steel mat.-no. 1.4435 (316L)		
G7.9		stainless steel mat.-no. 1.4435 (316L) with delta ferrite content < 3 %		
G9		others		
H2	gasket	O-ring (wetted parts), material EPDM, FDA compliant, USP Class VI compliant, temperature range -40...150 °C		
H2.1		O-ring (wetted parts), material EPDM, FDA compliant, USP Class VI compliant, incl. certificate, Temperaturbereich -40...150 °C		
H7		O-ring (wetted parts), material FKM (Viton), FDA compliant, USP Class VI compliant, temperature range -10...200 °C		
H7.1		O-ring (wetted parts), material FKM (Viton), FDA compliant, USP Class VI compliant, incl. certificate temperature range -10...200 °C		
H9		others		
A400		measuring device connection	directly	welded
A300	screwed G1/2			
A100	with temperature decoupler		screwed G1/2	
B40..	with capillary		welded	
B20..			screwed G1/2	
11	capillary lengths		1 m	
12			1.6 m	
13			2.5 m	
14			4 m	
21			5 m	
15			6 m	
23			7 m	
16			8 m	
17			10 m	
9		others		
	system filling ¹	<u>pressure transmission fluid</u>	<u>temperature range</u> ²	
L22		synthetic oil, free of silicone FD1, standard	-10...140 °C	
L23		synthetic oil, free of silicone FD1, pls. specify max. temperature	-40...230 °C	

Additional features (to be indicated in case of need, only)	
W1020	material certificate per EN 10204-3.1, wetted parts
W4035	electropolishing of wetted parts

Accessories			
MZ2090-A110	weld-on adapters	G1/2", Ø 29 mm	standard
MZ2090-A111			with inspection bore hole
MZ2090-A112			with Aufhalsung
MZ2090-A113			with inspection bore hole and Aufhalsung
MZ2090-A120		G3/4", Ø 40 mm	standard
MZ2090-A121			with inspection bore hole
MZ2090-A122			with Aufhalsung
MZ2090-A123			with inspection bore hole and Aufhalsung
MZ2090-A130		G1", Ø 40 mm	Standard
MZ2090-A131			with inspection bore hole
MZ2090-A132			with Aufhalsung
MZ2090-A133			with inspection bore hole and Aufhalsung
HY		surface roughness	hygienic version as per EHEDG and ASME BPE SF3
E7	material	stainless steel mat.-no. 1.4435 (316L)	
E7.9		stainless steel mat.-no. 1.4435 (316L) with delta ferrite content < 3 %	
E9		others	
W1020	material certificate per EN 10204-3.1, wetted parts		
W4035	electropolishing of wetted parts		

Order code (example): DE2160 - D120 - E7 - G7 - H2 - A400 - L22 - ...

¹ for more detailed information about pressure transmission fluids see TA_038
Please state temperature range to allow an accurate calculation of the system.

² max. media temperature for pressure > 0 bar rel. The temperature range of the used gasket has to be observed.