

Diaphragm seal for homogenizers Type series DD8020



Application area

- Food industry
- Pharmaceutical industry
- Biotechnology

Features

- Flush-mounted separating diaphragm of stainless steel
- Nominal pressure PN 600 and PN 1000
- Clamping flange, adjustable
- Volume optimised diaphragm base
- System fillings for different applications
- Measuring device connection:
 - directly welded
 - directly screwed
 - with capillary

Options

- Certificates
 - Material certificate acc. to EN 10204-3.1

Application

Suitable for mounting to bourdon tube pressure gauges and pressure transmitters. The diaphragm seal is used for high pressure applications and for high viscous media.

Technical data

Constructional design

Basic body:	Volume reduced diaphragm base Material: stainless steel mat.-no. 1.4404/1.4435 (316L)
Clamping flange:	Material: Stainless steel mat.-no. 1.4301 (304)
Diaphragm:	Flat diaphragm
Material wetted parts:	Diaphragm: Stainless steel mat.-no. 1.4435 (316L) Further materials upon request Basic body: Stainless steel mat.-no. 1.4404/1.4435 (316L)

Process connection

Design:	Clamping flange adjustable
Nominal pres- sure:	PN 600 and PN 1000

Special design:

A delivery without clamping flange is possible.

Sealing are not included in the scope of delivery.

Measuring device connection

See order details.

Material stainless steel mat.-no. 1.4301 (304)

System filling

See order details; further upon request.

Further details about pressure transmission fluids see general technical information TA_038.

Temperature error

In order to optimise the system we provide a detailed error calculation upon request.

Weight

With measuring device connection G1/2 approx. 1.1 kg

Further information about diaphragm seals see general technical information TA_031.

Measuring device connection

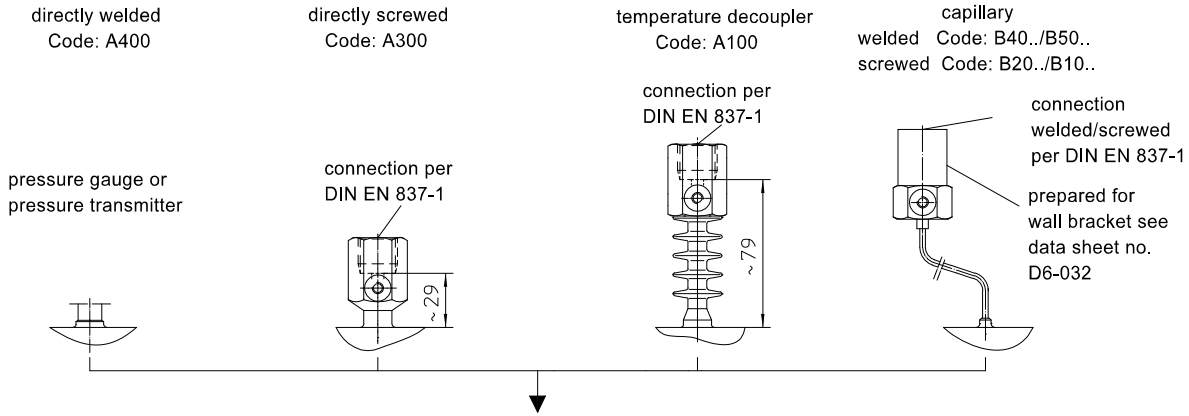

Dimensions

connection G1/2
per DIN EN 834-1

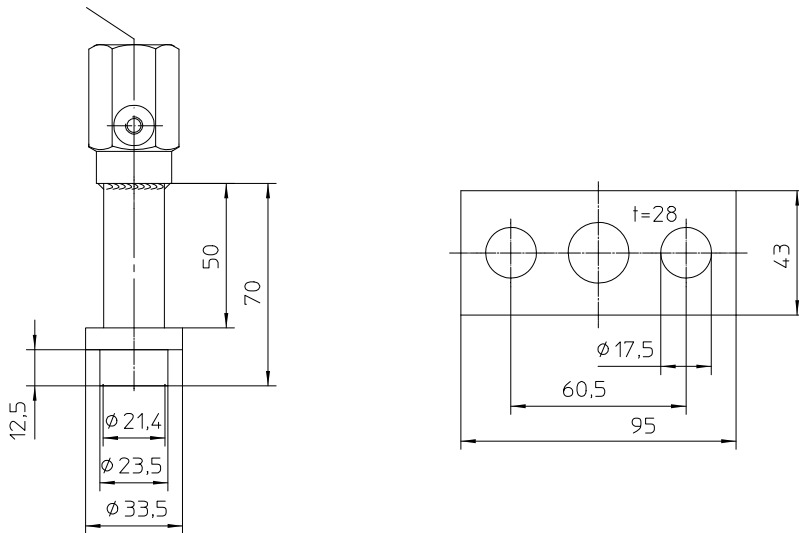

Order details

Diaphragm seal for homogenizers Type series DD8020

Order details diaphragm seal DD8020

DD8020	diaphragm seal for homogenizers		
G1	wetted parts	stainless steel mat.-no. 1.4404/1.4435 (316L)	
G9		variant	
K1	connection	clamping flange adjustable, material stainless steel	PN 600, standard
K3			PN 1000
K2		without clamping flange	
A100	measuring device connection	with temperature decoupler	screwed G1/2
A400		directly	welded
A300			screwed G1/2
B40 . .		with capillary	welded
B20 . .			screwed G1/2
B50 . .		with capillary and stainless steel protective tube	welded
B10 . .			screwed G1/2
11			1 m
12		1.6 m	
13		2.5 m	
14		4 m	
21		5 m	
15		6 m	
23	7 m		
16	8 m		
17	10 m		
9	capillary length	others	
	system filling ¹	<u>pressure transmission fluid</u>	<u>temperature range</u> ²
L22		synthetic oil, free of silicone FD1, standard	-10...140 °C
L23		synthetic oil, free of silicone FD1, pls. specify max. temperature	-40...230 °C
L15		glycerine/water FGW	-30...110 °C

Additional features (to be indicated in case of need, only)

W1020	material certificate per EN 10204-3.1, wetted parts
--------------	---

Order code (example): DD8020 - G1 - K1 - A400 - L22 - ...

¹ for more detailed information about pressure transmission fluids see TA_038.
Please state temperature range to allow an accurate calculation of the system.

² max. media temperature for pressures > 0 bar rel.